









ASSEMBLY INSTRUCTION

FRB60 - 6' HIGH FOOT END SLEIGH BED

HARDWARE LIST

PART LIST

NO	HARDWARE NAME	IMAGE	QTY (PCS)
1	NUTS M8*13		8 PCS
2	HALF MOON WASHER M8		8 PCS
3	SPRING WASHER M10		8 PCS
4	SPANNER 13		1 PCS
5	ALLEN KEY M4		1 PC
6	METAL THREAD M8*80		8 PCS
7	BOLT M6*40		2 PCS
8	WOODEN DOWEL		8 PCS
9	SCREW 4*30		26 PCS

A HEADBOARD = 1 PC

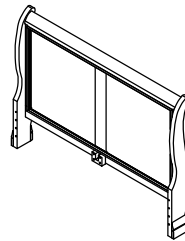

B FOOTBOARD = 1PC

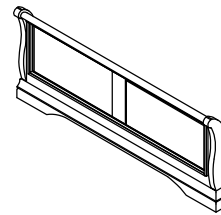

C SIDE RAILS = 2 PCS

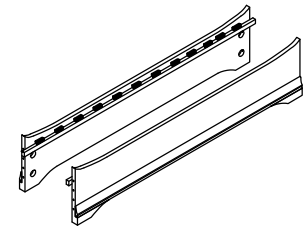

D SLATS = 13 PCS

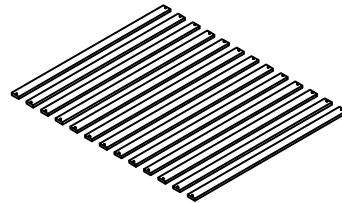

E CENTRE SUPPORT RAIL = 1 PC

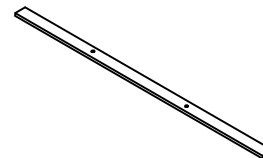

F CENTRE LEGS = 2 PCS

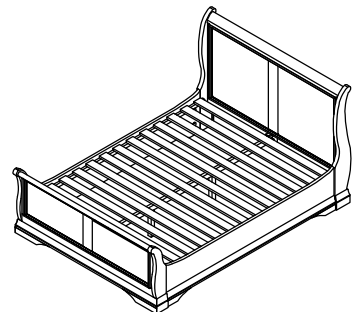
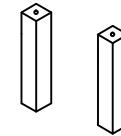

STEP 1

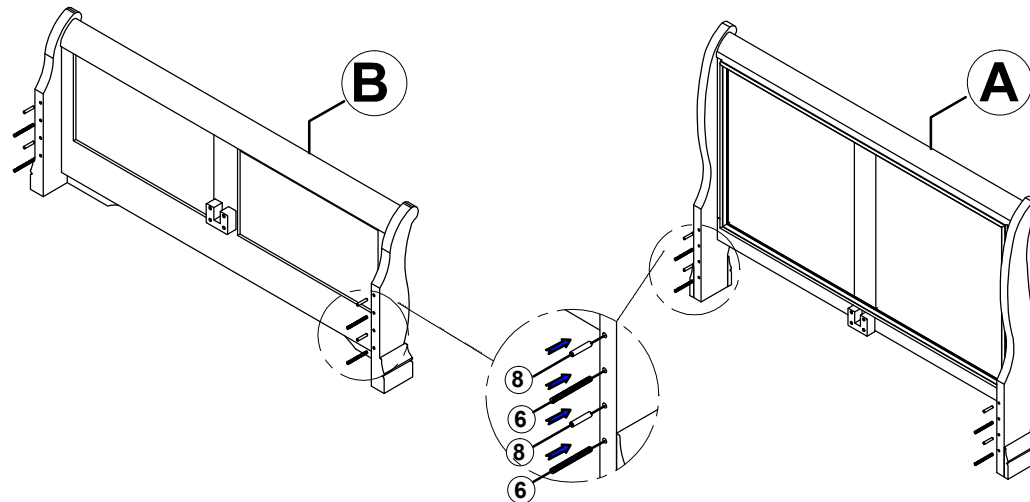

ASSEMBLY INSTRUCTION

FRB6 - 6' HIGH FOOT END SLEIGH BED

STEP 2

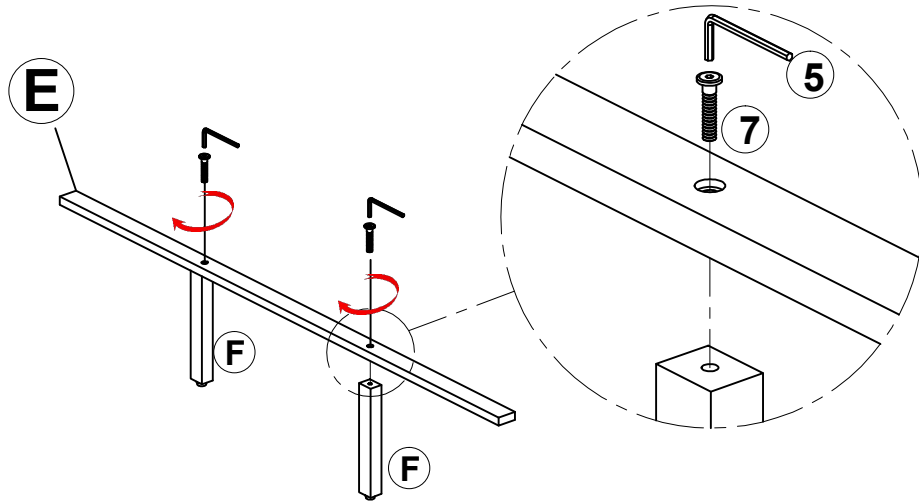

STEP 4

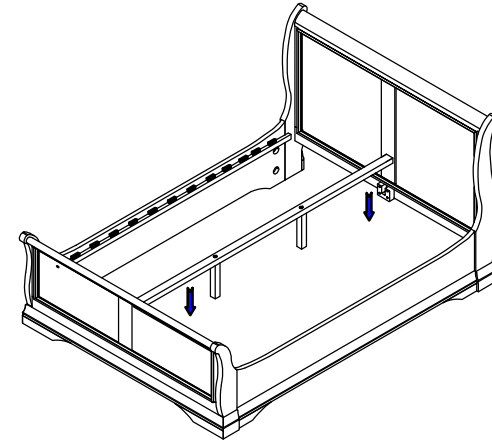

STEP 3

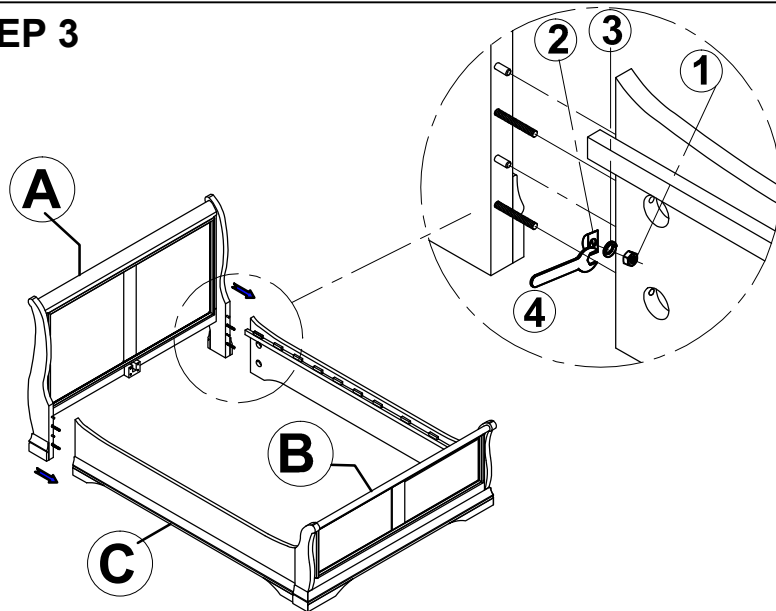

STEP 5

